

VALVE GATE SYSTEM OVERVIEW

Melt Design's patented pneumatic valve gate system is designed for easy maintenance with the mold in mind. Cleaning the debris catch zone is simple and accessible from the back by easily removing the piston using its internal threaded portion. The head clearance under each pin head allows for non-uniform pin lengths making them interchangeable.

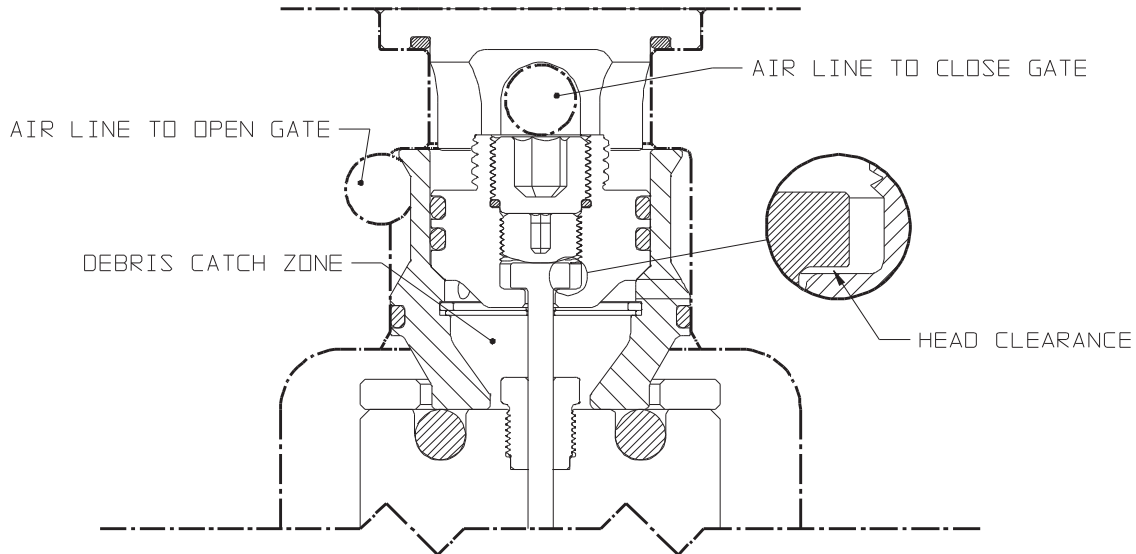

Typical valve gate assembly cross section view showing the valve gate parts inside the clamp plate.

TOPLESS

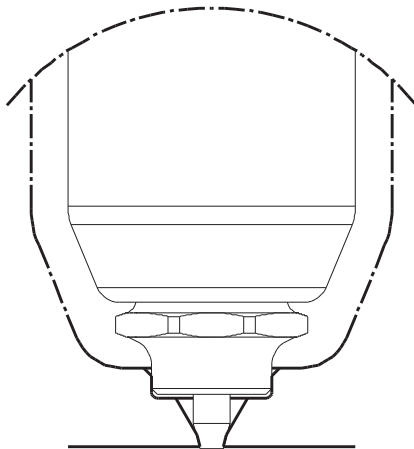

FULL BODY

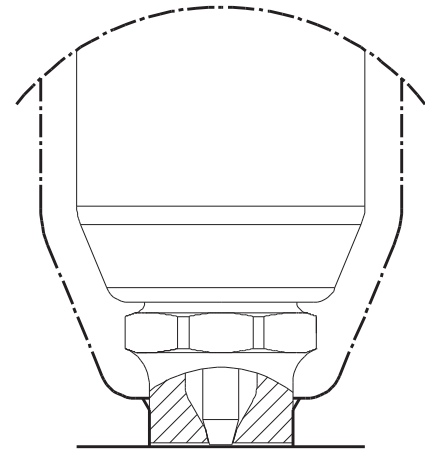

*Available in two tip styles and all sizes from small to extra large