

VALVE GATE TOPLESS (Small)

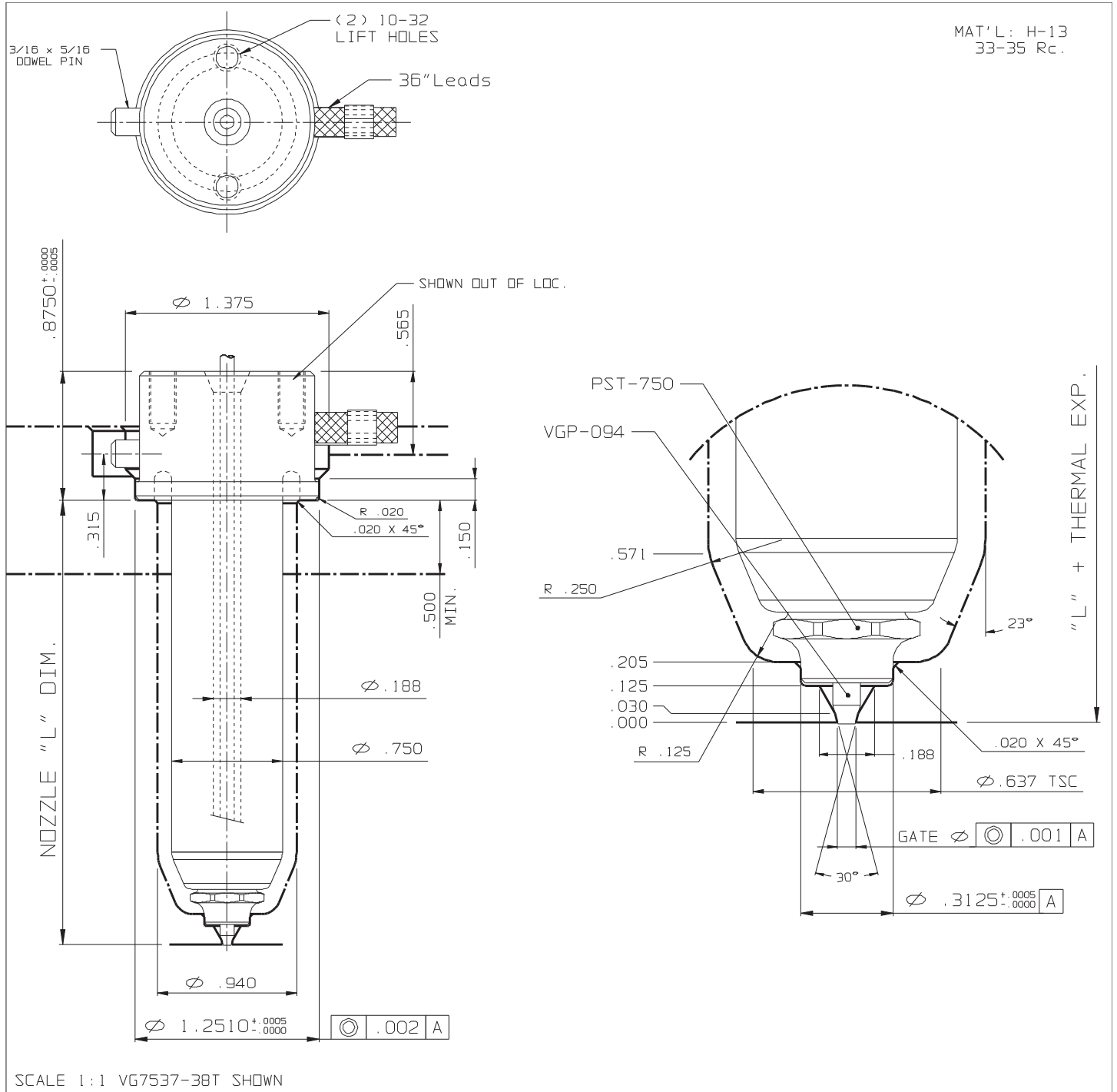

NOZZLE # (220 V)					THERMAL EXPANSION ΔL @ (°F)				OPTIONS	
L	FLAT TYPE	O-RING TYPE	WATTS	T/C	370°F	460°F	550°F	640°F	END CAP	GATE Ø
1.000	VG7517-38T	VG7517-68T	220	J2-06	0.002	0.003	0.004	0.004	PST-750	.040-.080
1.500	VG7523-38T	VG7523-68T	250	J2-06	0.003	0.004	0.005	0.006		
2.000	VG7527-38T	VG7527-68T	310	J2-06	0.004	0.006	0.007	0.008	VALVE PIN	
2.500	VG7533-38T	VG7533-68T	330	J2-06	0.005	0.007	0.009	0.010	VGP-094	
3.000	VG7537-38T	VG7537-68T	350	J2-10	0.006	0.008	0.010	0.012		
3.500	VG7543-38T	VG7543-68T	380	J2-10	0.007	0.010	0.012	0.014	STABILIZER	
4.000	VG7547-38T	VG7547-68T	400	J2-10	0.008	0.011	0.013	0.016		
4.500	VG7553-38T	VG7553-68T	500	J2-10	0.009	0.012	0.015	0.018	VGN-750	