

## VALVE GATE FULL BODY (Small)

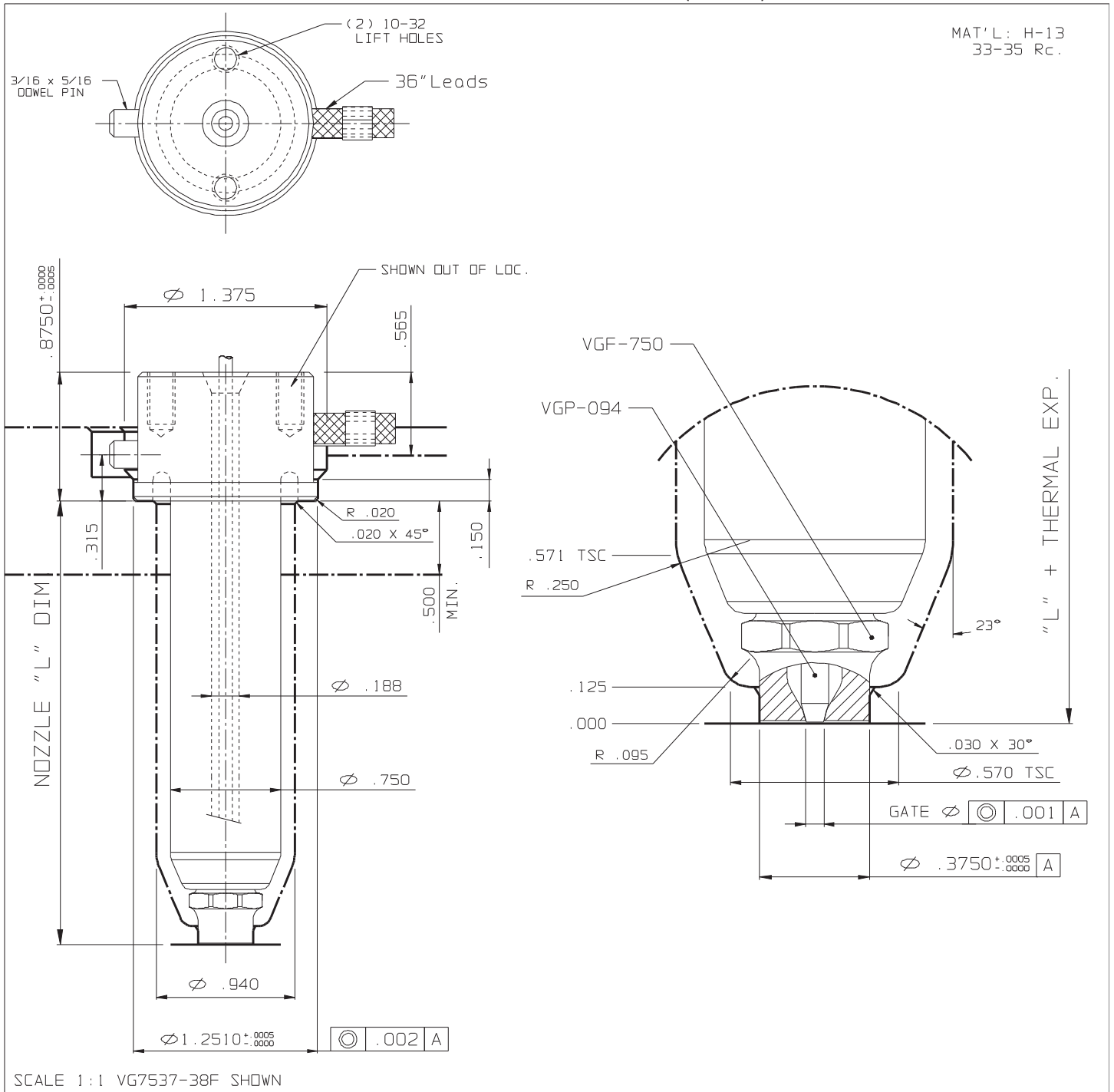

NOZZLE # (220 V)					THERMAL EXPANSION ΔL @ (°F)				OPTIONS	
L	FLAT TYPE	O-RING TYPE	WATTS	T/C	370°F	460°F	550°F	640°F	END CAP	GATE Ø
1.000	VG7517-38F	VG7517-68F	220	J2-06	0.002	0.003	0.004	0.004	VG7-750	.040
1.500	VG7523-38F	VG7523-68F	250	J2-06	0.003	0.004	0.005	0.006	VALVE PIN	VGP-094
2.000	VG7527-38F	VG7527-68F	310	J2-06	0.004	0.006	0.007	0.008		
2.500	VG7533-38F	VG7533-68F	330	J2-06	0.005	0.007	0.009	0.010	STABILIZER	VGN-750
3.000	VG7537-38F	VG7537-68F	350	J2-10	0.006	0.008	0.010	0.012		
3.500	VG7543-38F	VG7543-68F	380	J2-10	0.007	0.010	0.012	0.014		
4.000	VG7547-38F	VG7547-68F	400	J2-10	0.008	0.011	0.013	0.016		
4.500	VG7553-38F	VG7553-68F	500	J2-10	0.009	0.012	0.015	0.018		