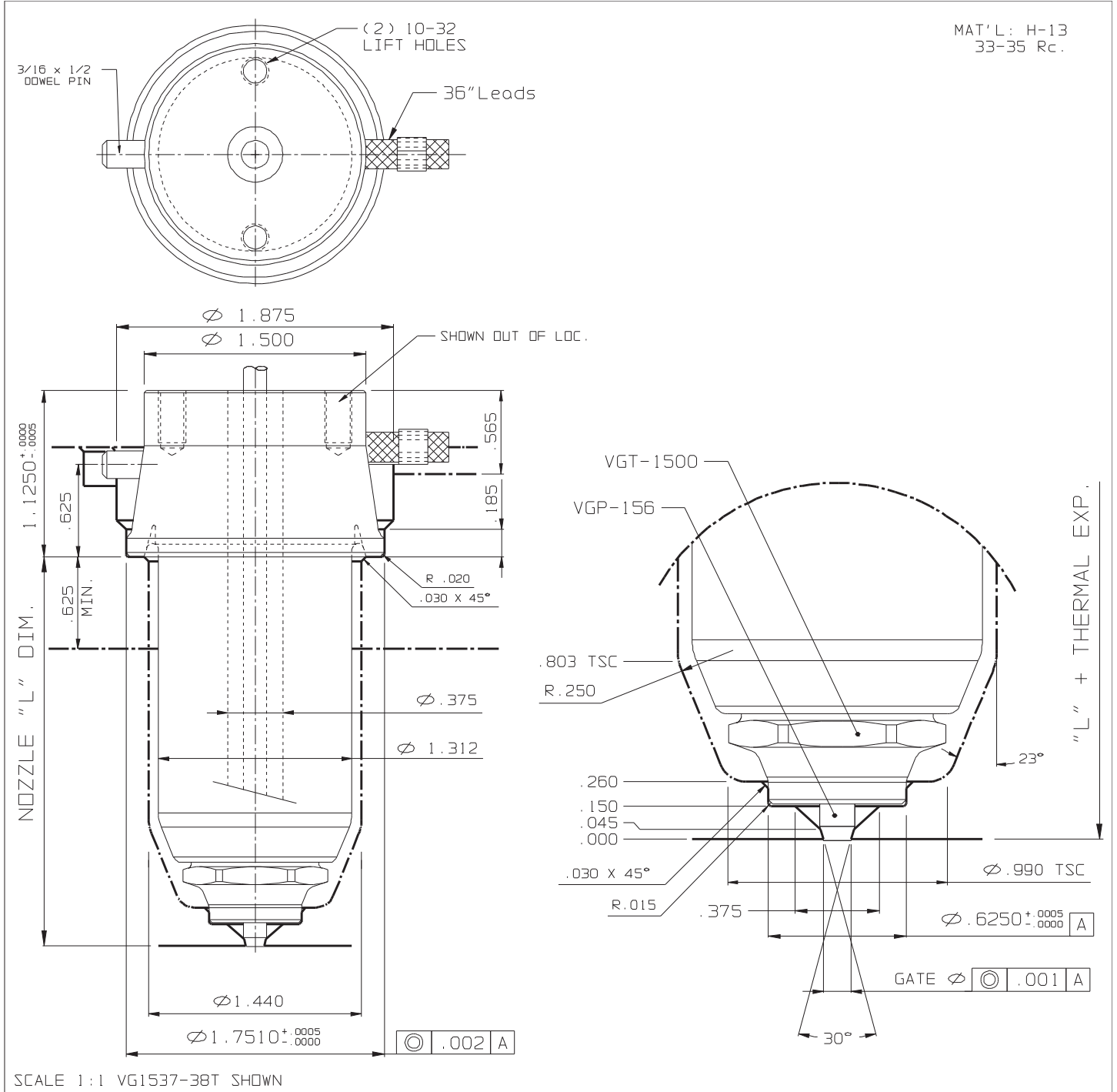

## VALVE GATE TOPLESS (Large)

 MAT'L: H-13  
 33-35 Rc.

NOZZLE # (220V)					THERMAL EXPANSION ΔL @ (°F)				OPTIONS	
L	FLAT TYPE	O-RING TYPE	WATTS	T/C	370°F	460°F	550°F	640°F	END CAP	GATE Ø
1.625	VG1527-38T	VG1527-68T	410	J2-06	0.003	0.005	0.006	0.007	VGT-1500	.100-.125
2.125	VG1533-38T	VG1533-68T	450	J2-06	0.004	0.006	0.007	0.009		
2.625	VG1537-38T	VG1537-68T	480	J2-06	0.005	0.007	0.009	0.011	VALVE PIN	
3.125	VG1543-38T	VG1543-68T	530	J2-10	0.006	0.009	0.011	0.013	VGP-156	
3.625	VG1547-38T	VG1547-68T	560	J2-10	0.007	0.010	0.012	0.015	STABILIZER	
4.125	VG1553-38T	VG1553-68T	600	J2-10	0.008	0.011	0.014	0.016	VGN-1500	
4.625	VG1557-38T	VG1557-68T	630	J2-10	0.009	0.013	0.016	0.018		
5.125	VG1563-38T	VG1563-68T	650	J2-10	0.010	0.014	0.017	0.020		