

## VALVE GATE TOPLESS (Medium)

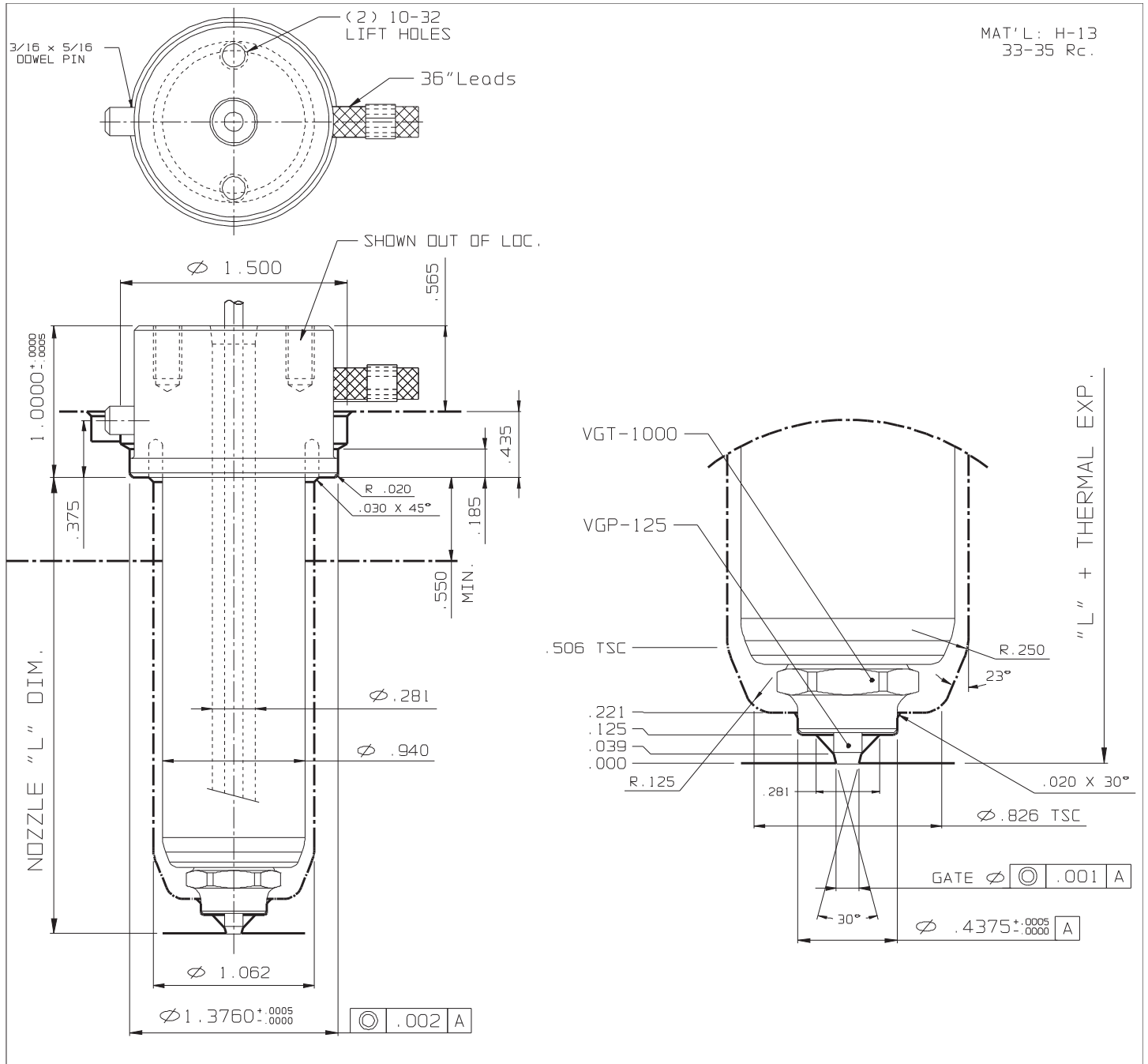

SCALE 1:1 VG1040-38T SHOWN

NOZZLE # (220V)					THERMAL EXPANSION ΔL @ (°F)				OPTIONS	
L	FLAT TYPE	O-RING TYPE	WATTS	T/C	370°F	460°F	550°F	640°F	END CAP	GATE Ø
2.000	VG1030-38T	VG1030-68T	355	J2-06	0.004	0.006	0.007	0.008	VGT-1000	.060-100
2.500	VG1035-38T	VG1035-68T	415	J2-06	0.005	0.007	0.009	0.010	VALVE PIN	VGP-125
3.000	VG1040-38T	VG1040-68T	470	J2-10	0.006	0.008	0.010	0.012		
3.500	VG1045-38T	VG1045-68T	530	J2-10	0.007	0.010	0.012	0.014	STABILIZER	VGN-1000
4.000	VG1050-38T	VG1050-68T	590	J2-10	0.008	0.011	0.013	0.016		
4.500	VG1055-38T	VG1055-68T	590	J2-10	0.009	0.012	0.015	0.018		
5.000	VG1060-38T	VG1060-68T	610	J2-10	0.010	0.014	0.017	0.020		
5.500	VG1065-38T	VG1065-68T	660	J2-10	0.011	0.015	0.018	0.022		
6.000	VG1070-38T	VG1070-68T	710	J2-10	0.012	0.016	0.020	0.024		