

EDGE GATE (SINGLE BODY)

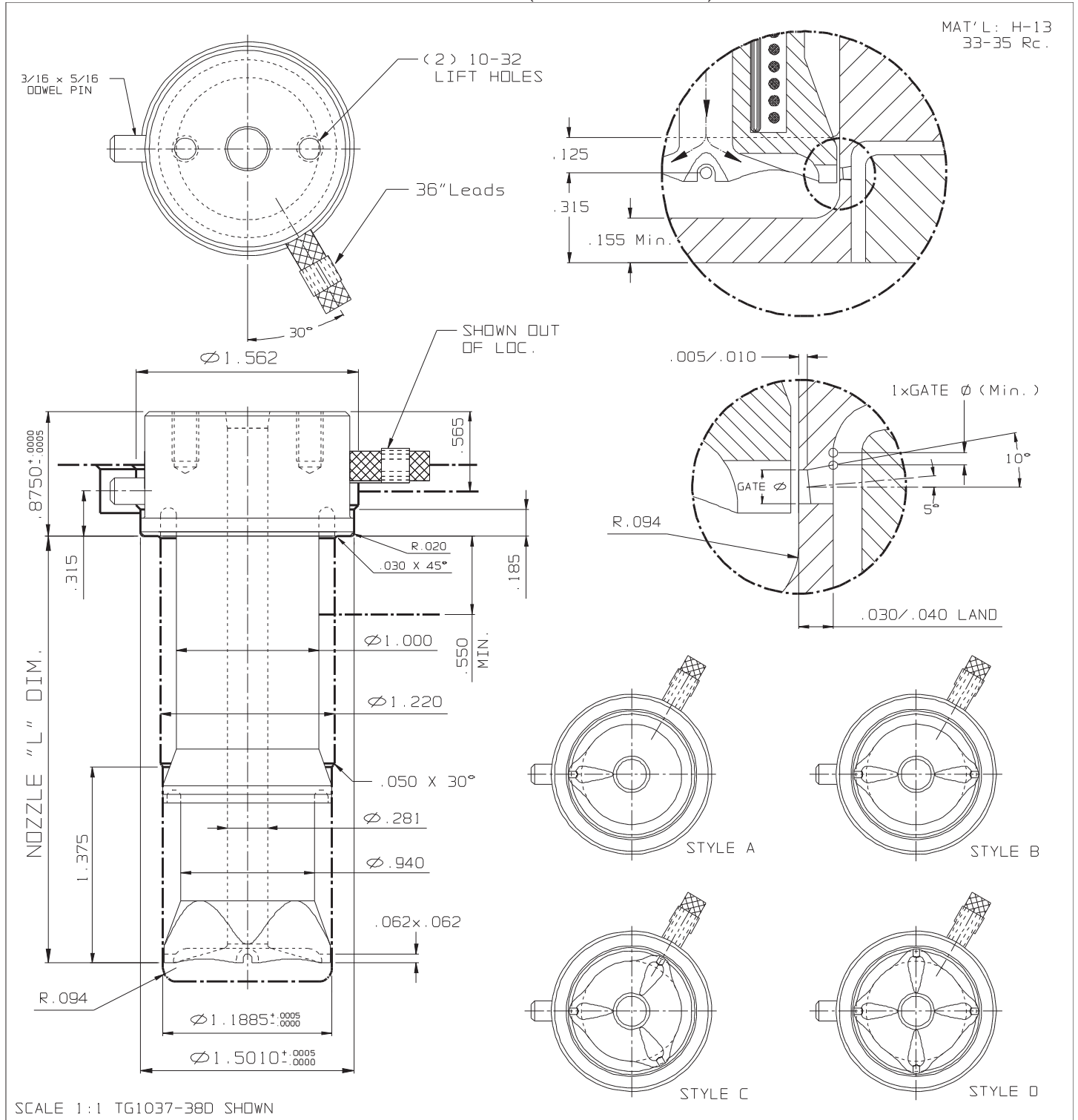

NOZZLE # (220V)					THERMAL EXPANSION ΔL @ (°F)				ORDERING
L	FLAT TYPE	O-RING TYPE	WATTS	T/C	370°F	460°F	550°F	640°F	
2.000	TG1027-38(#)	TG1027-68(#)	340	J2-06	0.004	0.006	0.007	0.009	When ordering, please substitute the (#) with the desired style to complete nozzle part number. Example: TG1033-38D
2.500	TG1033-38(#)	TG1033-68(#)	400	J2-06	0.005	0.007	0.009	0.011	
3.000	TG1037-38(#)	TG1037-68(#)	455	J2-06	0.006	0.009	0.011	0.013	
3.500	TG1043-38(#)	TG1043-68(#)	515	J2-06	0.007	0.010	0.012	0.015	
4.000	TG1047-38(#)	TG1047-68(#)	575	J2-10	0.008	0.011	0.014	0.016	
4.500	TG1053-38(#)	TG1053-68(#)	575	J2-10	0.009	0.013	0.016	0.018	