

EDGE GATE (REPLACEABLE TIP)

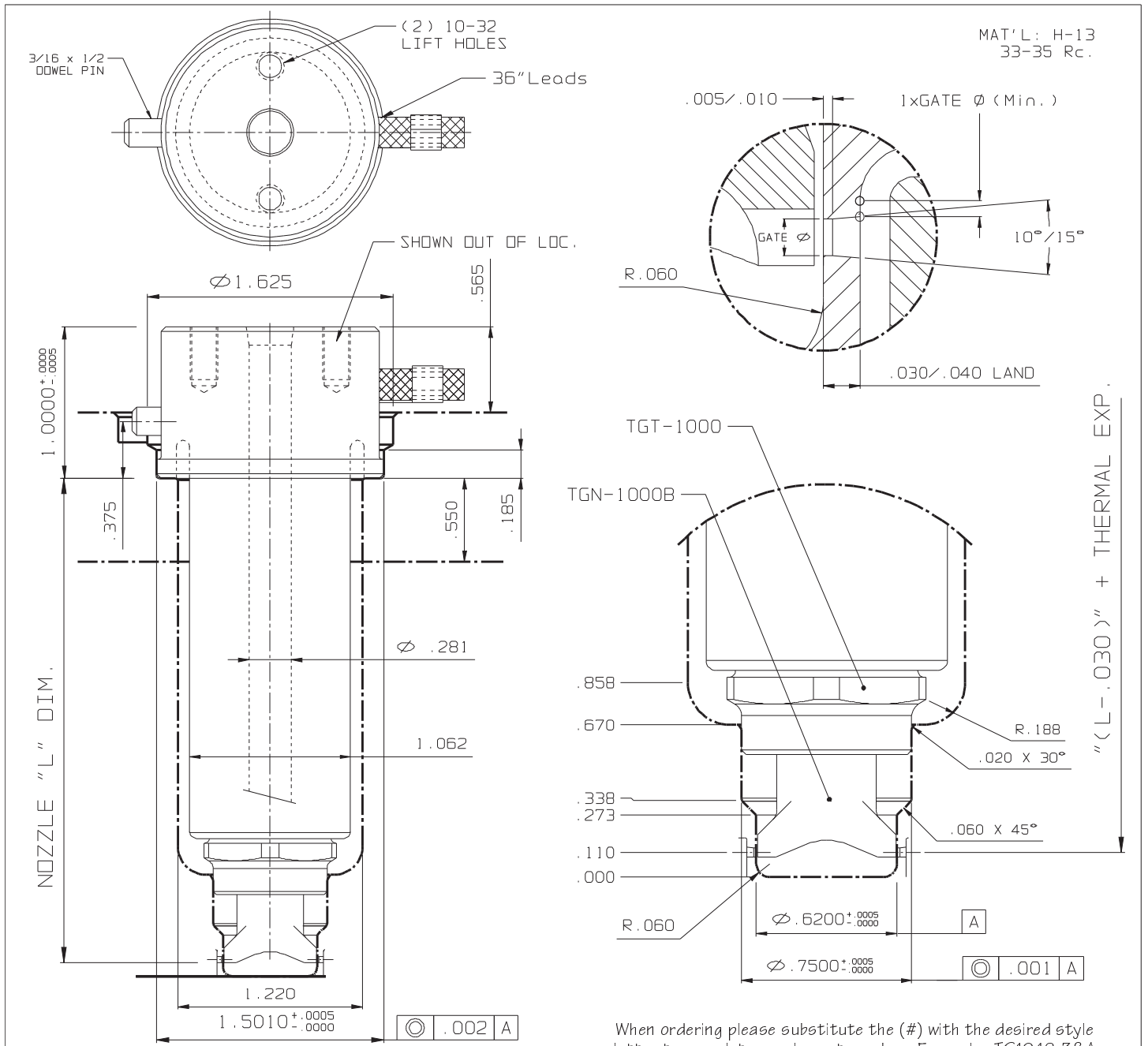

SCALE 1:1 TG1042-38B SHOWN

When ordering please substitute the (#) with the desired style letter to complete nozzle part number. Example: TG1042-38A
 A=Single Gate B=Two Gates C=Three Gates D=Four Gates

NOZZLE # (220V)					THERMAL EXPANSION ΔL @ (°F)				OPTIONS	
L	FLAT TYPE	O-RING TYPE	WATTS	T/C	370°F	460°F	550°F	640°F	END CAP	GATE Ø
1.700	TG1026-38(#)	TG1026-68(#)	325	J2-06	0.004	0.005	0.007	0.008	TGT-1000	.030-.060
2.200	TG1032-38(#)	TG1032-68(#)	385	J2-06	0.005	0.007	0.008	0.010		
2.700	TG1036-38(#)	TG1036-68(#)	440	J2-10	0.006	0.008	0.010	0.012		
3.200	TG1042-38(#)	TG1042-68(#)	500	J2-10	0.007	0.009	0.011	0.014		
3.700	TG1046-38(#)	TG1046-68(#)	560	J2-10	0.008	0.011	0.013	0.016	GATING NEEDLES	
4.200	TG1052-38(#)	TG1052-68(#)	560	J2-10	0.009	0.012	0.015	0.017	UNFILLED MAT'LS	REINFORCED MAT'LS
4.700	TG1056-38(#)	TG1056-68(#)	610	J2-10	0.010	0.013	0.016	0.019	TGN-1000A	TGN-1010A
5.200	TG1062-38(#)	TG1062-68(#)	660	J2-10	0.011	0.015	0.018	0.021	TGN-1000B	TGN-1010B
5.700	TG1066-38(#)	TG1066-68(#)	710	J2-10	0.012	0.016	0.019	0.022	TGN-1000C	TGN-1010C
									TGN-1000D	TGN-1010D