

## THROUGH TIP (Large)

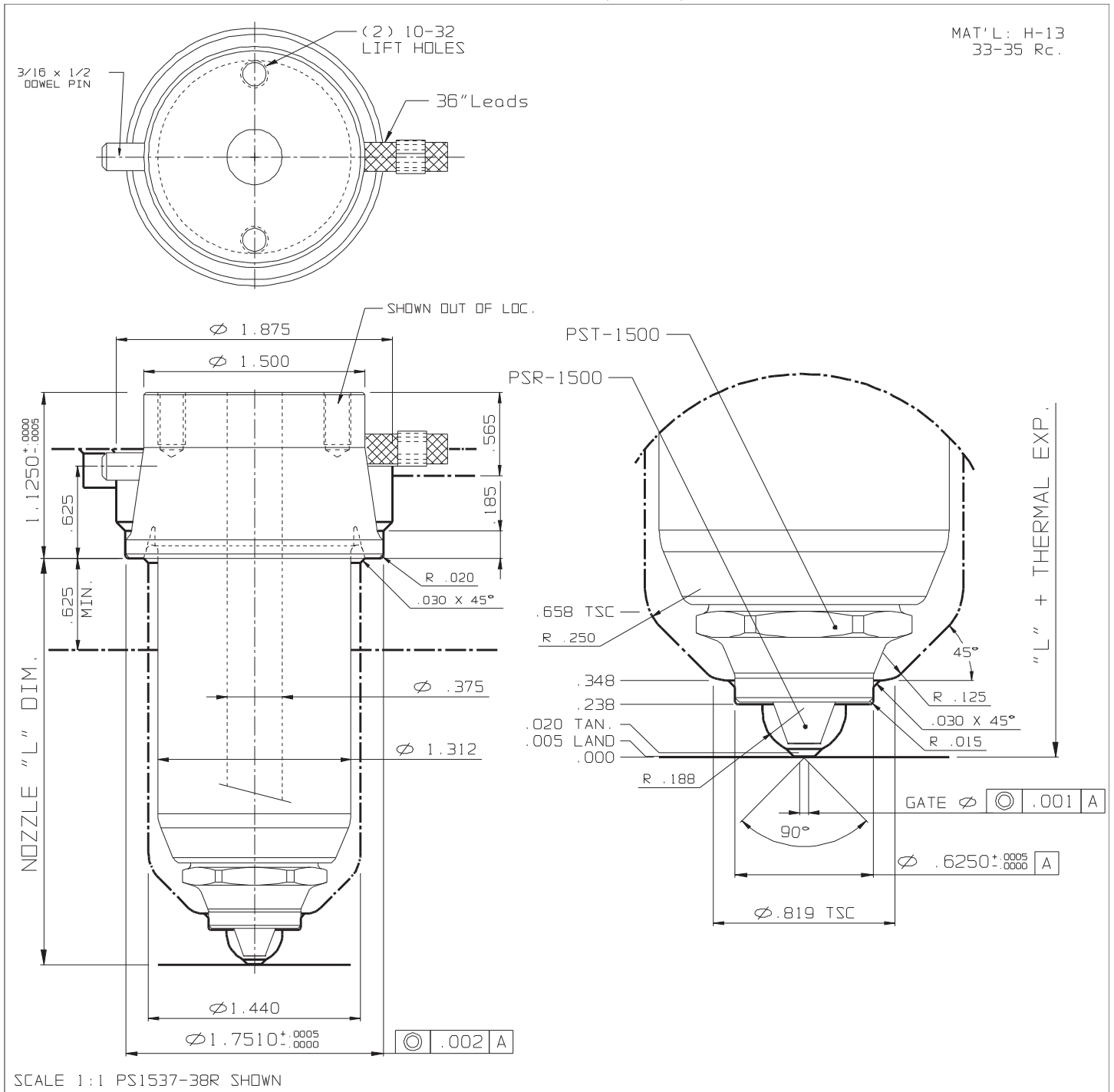

NOZZLE # (220V)					THERMAL EXPANSION ΔL @ (°F)				OPTIONS	
L	FLAT TYPE	O-RING TYPE	WATTS	T/C	370°F	460°F	550°F	640°F	END CAP	GATE Ø
1.750	PS1527-38R	PS1527-68R	410	J2-06	0.004	0.005	0.007	0.008	PST-1500	.094 - .125
2.250	PS1533-38R	PS1533-68R	450	J2-06	0.005	0.007	0.008	0.010		
2.750	PS1537-38R	PS1537-68R	480	J2-06	0.006	0.008	0.010	0.012		
3.250	PS1543-38R	PS1543-68R	530	J2-10	0.007	0.009	0.011	0.014	GATING NEEDLES	
3.750	PS1547-38R	PS1547-68R	560	J2-10	0.008	0.011	0.013	0.016	UNFILLED MAT'LS	REINFORCED MAT'LS
4.250	PS1553-38R	PS1553-68R	600	J2-10	0.009	0.012	0.015	0.017	PSR-1500	PSR-1510
4.750	PS1557-38R	PS1557-68R	630	J2-10	0.010	0.013	0.016	0.019		
5.250	PS1563-38R	PS1563-68R	650	J2-10	0.011	0.015	0.018	0.021		