

NOTE: Final stock height depends on processing temperature.
Please call MDI for clearance requirements.

INSTALLATION REQUIREMENTS

FOR TYPE "I" MANIFOLDS

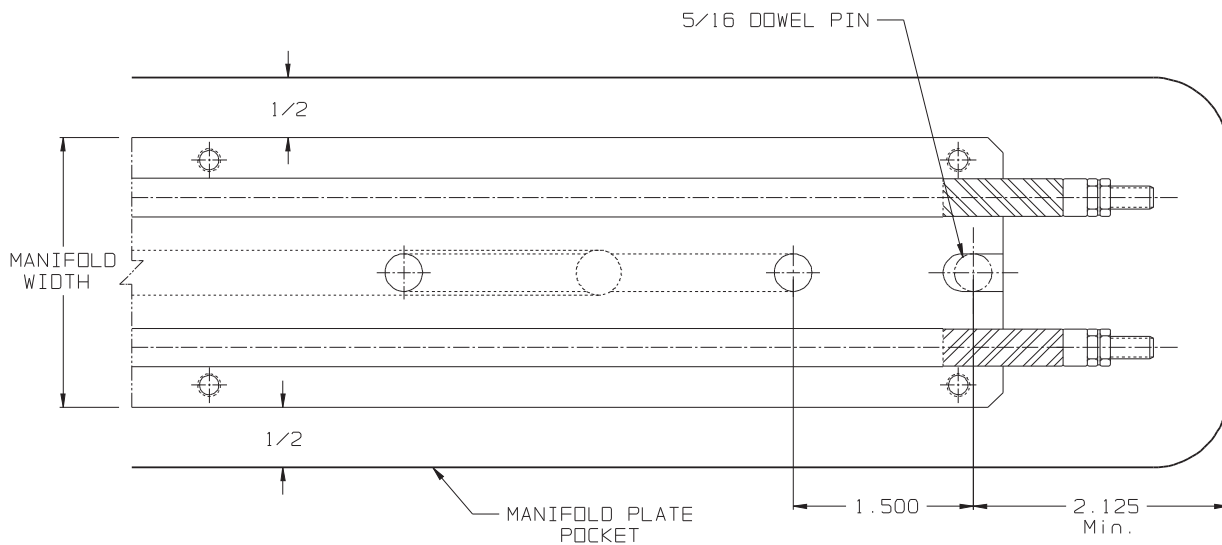
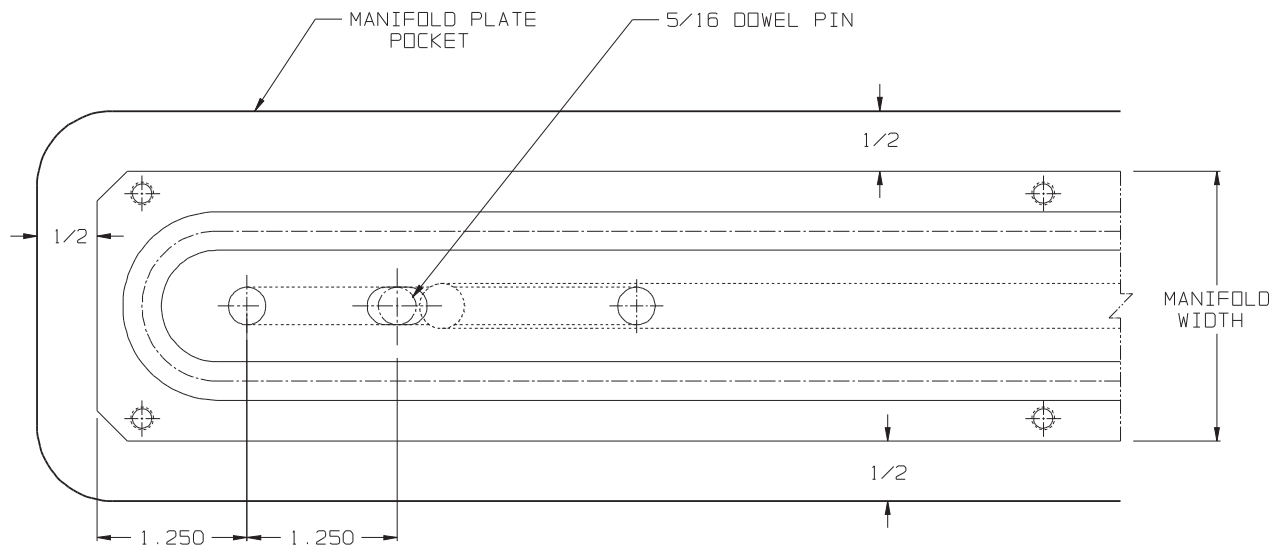

NOTE: Final stock height depends on processing temperature.
Please call MDI for clearance requirements.

INSTALLATION REQUIREMENTS

FOR ALL TYPE MANIFOLDS

