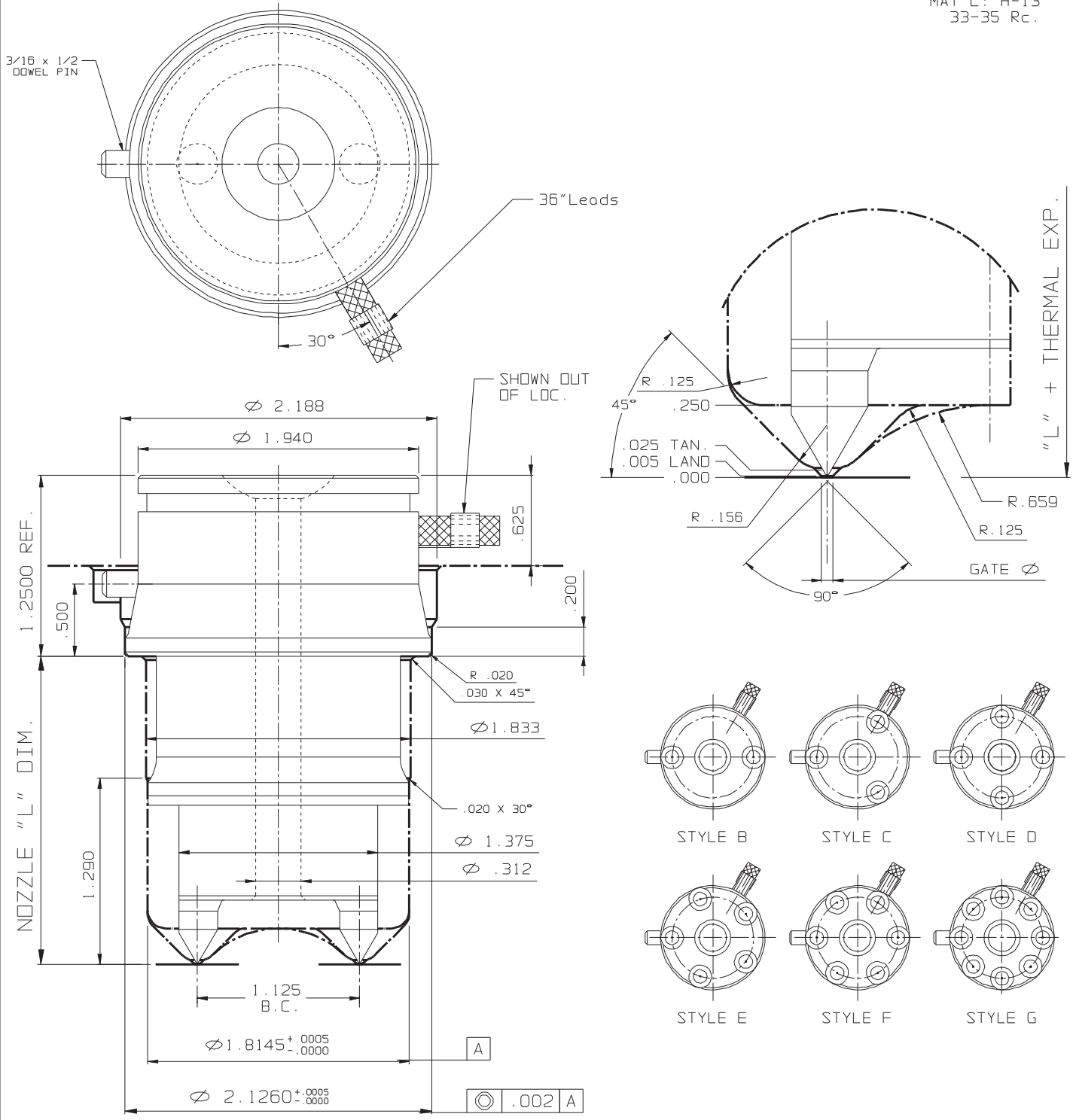

## MULTI-TIP

 MAT'L: H-13  
 33-35 Rc.

SCALE 1:1 MT1533-50B SHOWN

NOZZLE # (220 V)					THERMAL EXPANSION ΔL @ (°F)				OPTIONS
L	½ SPH. RAD.	¾ SPH. RAD.	WATTS	T/C	370°F	460°F	550°F	640°F	When ordering, please substitute the (#) with the desired style letter to complete nozzle part number. Example: MT1533-50D
2.125	MT1533-50(#)	MT1533-75(#)	550	J2-06	0.005	0.007	0.008	0.010	
2.625	MT1537-50(#)	MT1537-75(#)	640	J2-06	0.006	0.008	0.010	0.012	
3.125	MT1543-50(#)	MT1543-75(#)	640	J2-06	0.007	0.009	0.011	0.014	