

INTERNALLY HEATED MOLDING MACHINE NOZZLES

- Replaces existing Externally Heated Nozzles
- Removable thermocouple for accurate temperature reading
- Armor cable protects the leads and thermocouple
- Threaded and sized for your molding machine
- Accurate melt distribution along the nozzle

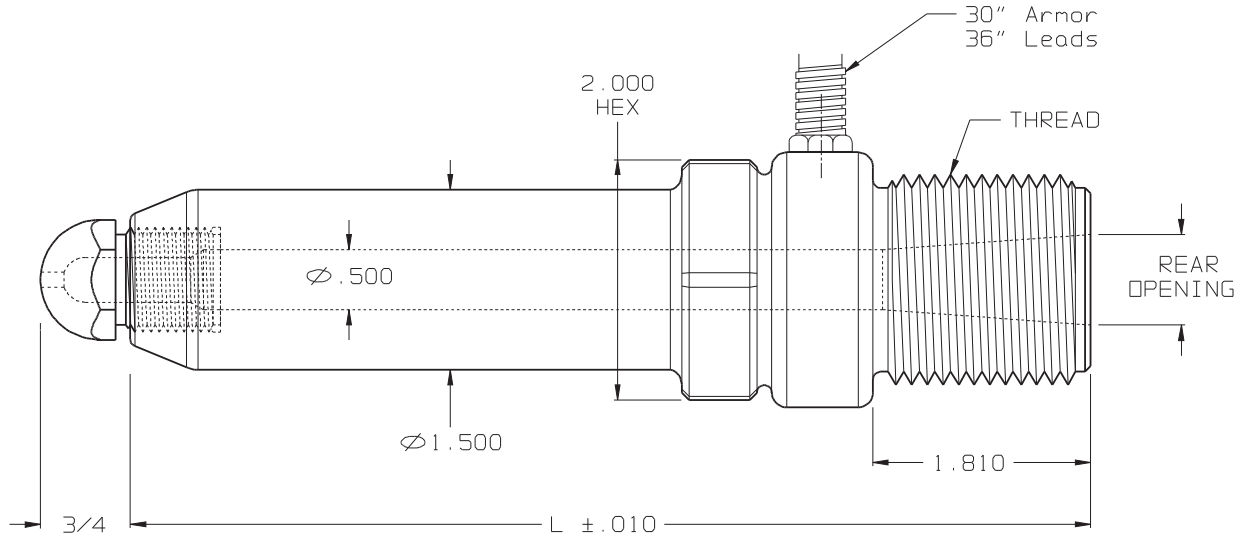

PART NO.	STANDARD "L"	WATTS	VOLTS*	T/C	STD. THREAD	REAR OPENING	OPTIONAL
MN124-6.00	6.00	700	240V	J2-10 OR K2-10	1 1/2 x 12	SPECIFY	NOZZLE TIPS AND 60° ELBOW
MN124-8.00	8.00	800		J2-14 OR K2-14			
MN124-10.00	10.00	1000			J2-24 OR K2-24		
MN124-12.00	12.00	1250		1 3/4 x 8			
MN124-13.00	13.00	1400					
MN124-14.00	14.00	1500					

Note: For thread sizes other than standard an additional charge will apply.

*Dual Zone Nozzles and other voltages available upon request.

INDUSTRY'S STANDARD NOZZLE TIPS

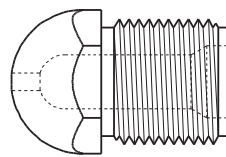

General Type

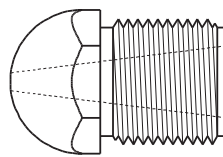

Full Taper

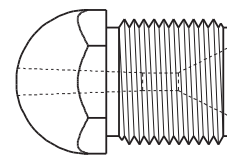

Nylon Type

RADIUS	GENERAL TYPE	FULL TAPER	NYLON TYPE	THREAD
1/2 R	GT-50	FT-50	NT-50	7/8 -14
3/4 R	GT-75	FT-75	NT-75	7/8 -14

Nozzle Tips are available with 1/8 and 3/16 Dia. Orifice.