

## FULL BODY (Extra Large)

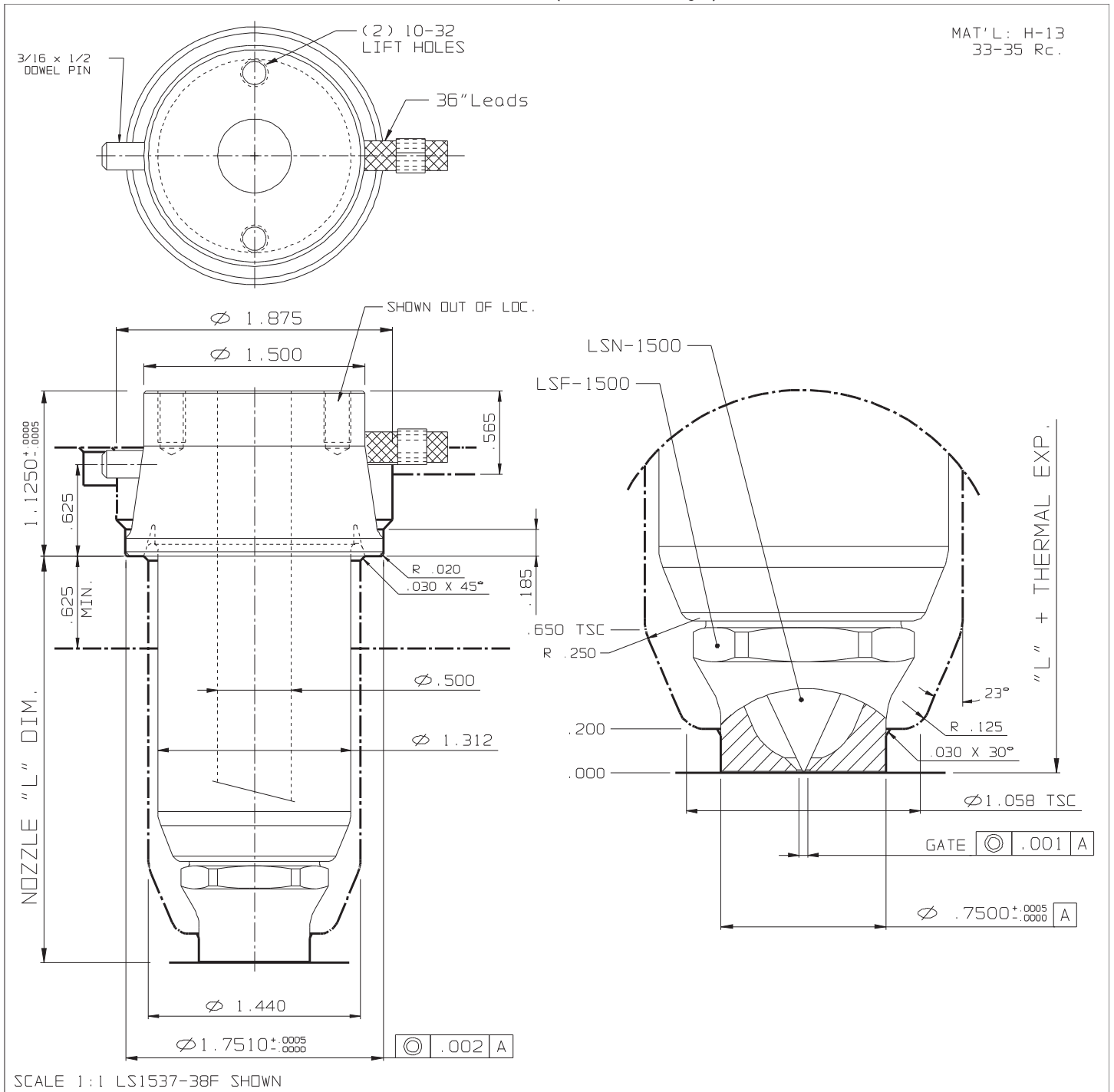

NOZZLE # (220V)					THERMAL EXPANSION ΔL @ (°F)				OPTIONS	
L	FLAT TYPE	O-RING TYPE	WATTS	T/C	370°F	460°F	550°F	640°F	END CAP	GATE Ø
1.750	LS1527-38F	LS1527-68F	410	J2-06	0.004	0.005	0.007	0.008		
2.250	LS1533-38F	LS1533-68F	450	J2-06	0.005	0.007	0.008	0.010	LSF-1500	.060-.094
2.750	LS1537-38F	LS1537-68F	480	J2-06	0.006	0.008	0.010	0.012		
3.250	LS1543-38F	LS1543-68F	530	J2-10	0.007	0.009	0.011	0.014		
3.750	LS1547-38F	LS1547-68F	560	J2-10	0.008	0.011	0.013	0.016		
4.250	LS1553-38F	LS1553-68F	600	J2-10	0.009	0.012	0.015	0.017		
4.750	LS1557-38F	LS1557-68F	630	J2-10	0.010	0.013	0.016	0.019		
5.250	LS1563-38F	LS1563-68F	650	J2-10	0.011	0.015	0.018	0.021		
GATING NEEDLES										
					UNFILLED MAT'LS	REINFORCED MAT'LS				
					LSN-1500	LSN-1510				