

EXTENDED TIP (Small)

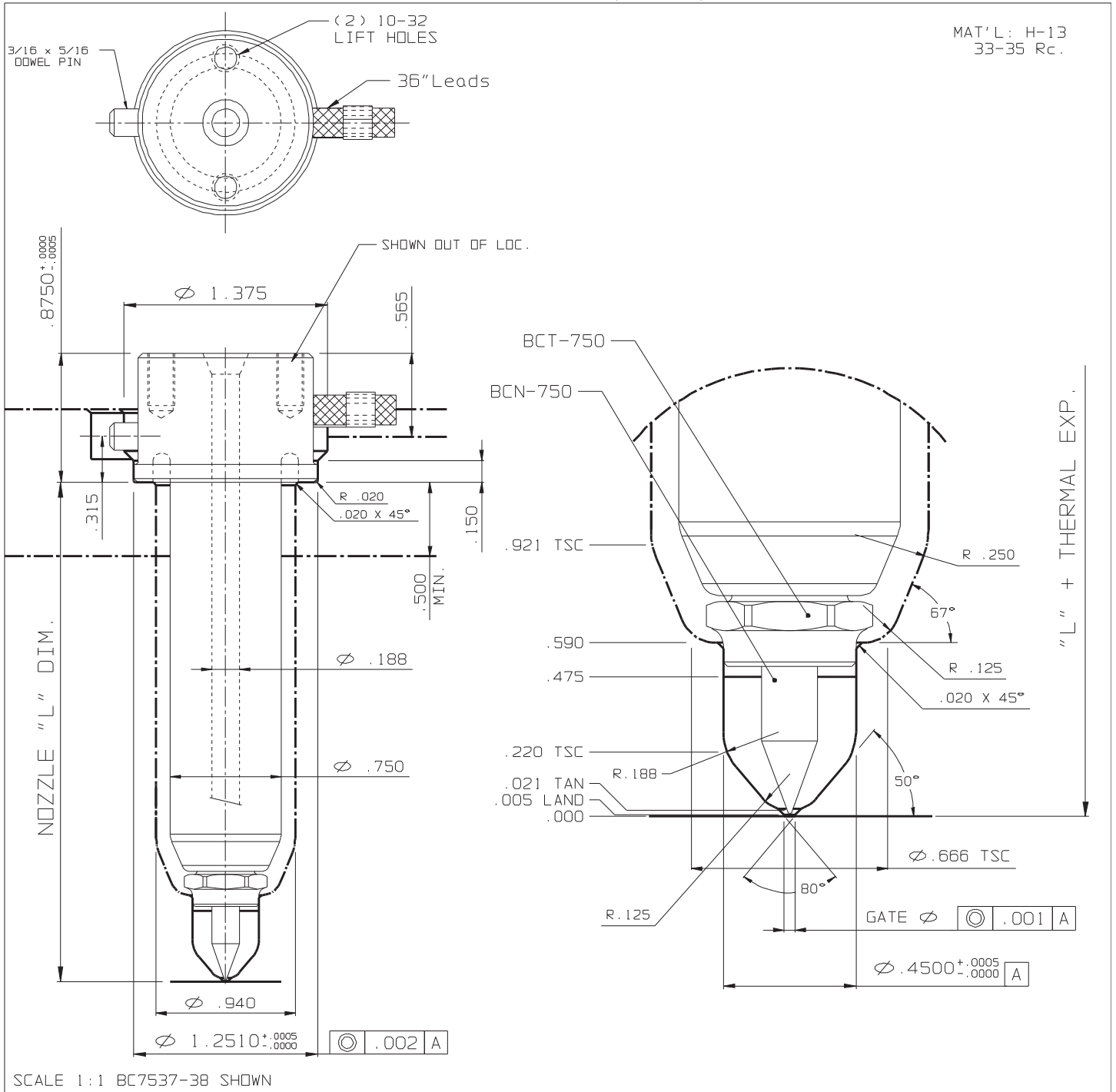

NOZZLE # (220 V)					THERMAL EXPANSION ΔL @ (°F)				OPTIONS	
L	FLAT TYPE	O-RING TYPE	WATTS	T/C	370°F	460°F	550°F	640°F	END CAP	GATE Ø
1.375	BC7517-38	BC7517-68	220	J2-06	0.003	0.004	0.005	0.006	BCT-750	.030 - .060
1.875	BC7523-38	BC7523-68	250	J2-06	0.004	0.006	0.007	0.008		
2.375	BC7527-38	BC7527-68	310	J2-06	0.005	0.007	0.009	0.010		
2.875	BC7533-38	BC7533-68	330	J2-06	0.006	0.008	0.010	0.012	GATING NEEDLES	
3.375	BC7537-38	BC7537-68	350	J2-10	0.007	0.010	0.012	0.014	UNFILLED MAT'LS	REINFORCED MAT'LS
3.875	BC7543-38	BC7543-68	380	J2-10	0.008	0.011	0.013	0.016	BCN-750	BCN-760
4.375	BC7547-38	BC7547-68	400	J2-10	0.009	0.012	0.015	0.018		
4.875	BC7553-38	BC7553-68	500	J2-10	0.010	0.014	0.017	0.020		