

## BUSHING HEAD KEYING LIMITATIONS

When keying is required on any Melt Design standard sprue bushing, please follow the machining limits given below.

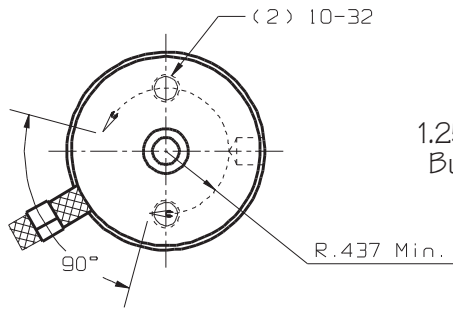

1.250/1.500 Dia.  
Bushing Heads

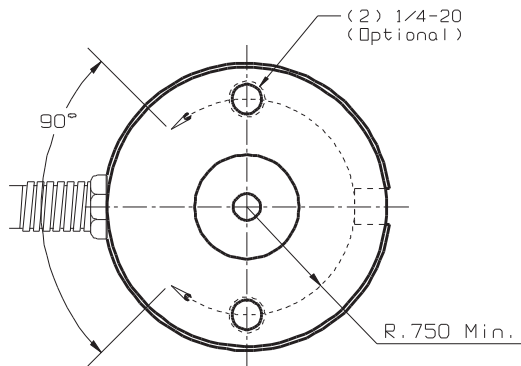
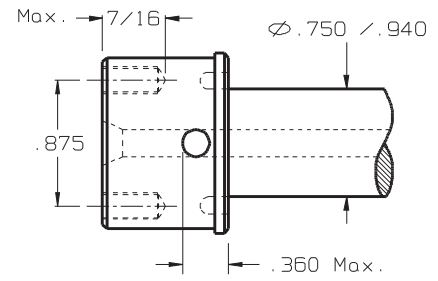

.750 Dia.  
Bushing

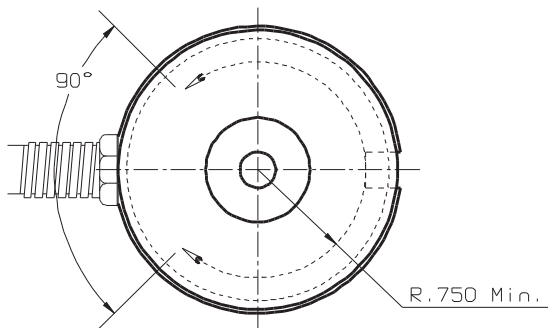
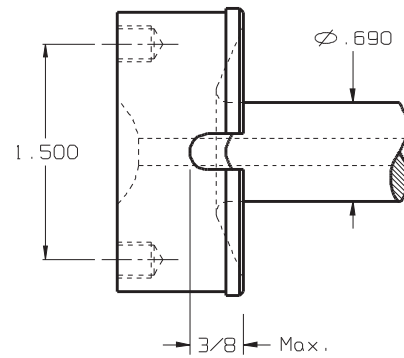

1.000 Dia  
Bushing

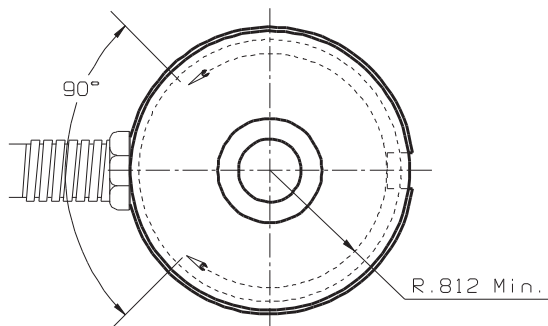
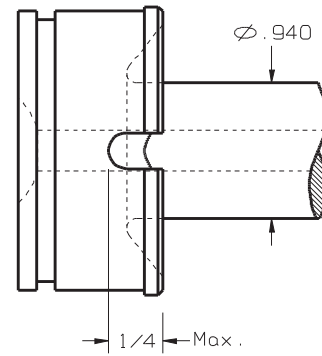

1.500 Dia.  
Bushing

